

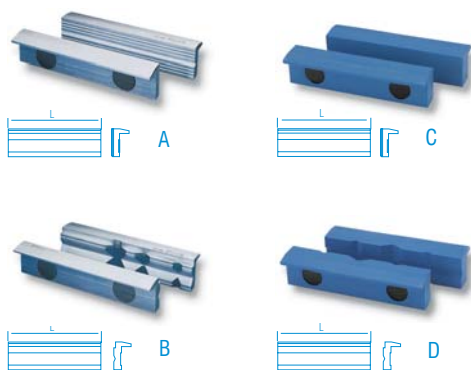

6010 - MORDAZAS PARA TORNILLO DE BANCO

ACESA PALMERA IRIMO



Ref.	Código	L	
1250400	6010.A2100	100	A
1250401	6010.A2125	125	
1250402	6010.A2150	150	
1250403	6010.A1100	100	B
1250404	6010.A1125	125	
1250405	6010.A1150	150	
1250406	6010.P2100	100	C
1250407	6010.P2125	125	
1250408	6010.P2150	150	
1250409	6010.P1100	100	D
1250410	6010.P1125	125	
1250411	6010.P1150	150	

604 - TORNILLO DE SOBREMESA

ACESA PALMERA IRIMO

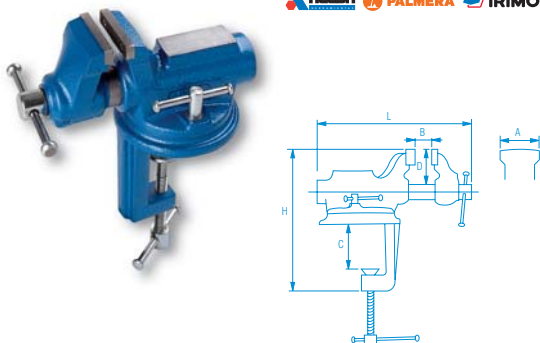

Ref.	Código	L	A	B	C	D	H
1250500	6040.00630	210	63	60	75	47	225



1B - TORNILLO DE BANCO PARA MECÁNICOS

IRWIN

Novedad



Ref.	Código	Anchura mordazas	Profundidad mordazas	
1250600	1B	75	50	1
1250601	3B	100	70	1
1250602	4B	115	80	1
1250603	5B	125	85	1
1250604	6B	150	90	1
1250605	8B	205	100	1

SARGENTOS

SARGENTO DE APRIETE MODELO E

PHER

Sección de llanta 30 x 8

Ref.	Código	b cm	Alcance cm
1250700	E10	10	8,5
1250701	E15	15	8,5
1250702	E20	20	8,5
1250703	E25	25	8,5
1250704	E30	30	8,5
1250705	E40	40	8,5
1250706	E50	50	8,5
1250707	E60	60	8,5



SARGENTO DE APRIETE MODELO F

PHER

Sección de llanta 35 x 8

Ref.	Código	b cm	Alcance cm
1250800	F20	20	12
1250801	F25	25	12
1250802	F30	30	12
1250803	F35	35	12
1250804	F40	40	12
1250805	F45	45	12
1250806	F50	50	12
1250807	F60	60	12
1250808	F70	70	12
1250809	F80	80	12
1250810	F90	90	12
1250811	F100	100	12
1250812	F110	110	12
1250813	F120	120	12
1250814	F130	130	12
1250815	F140	140	12
1250816	F150	150	12
1250817	F200	200	12





SARGENTO DE APRIETE MODELO R

Sección de llanta 40 x 10

Ref.	Código	b cm	Alcance cm
1250900	R20	20	15
1250901	R25	25	15
1250902	R30	30	15
1250903	R35	35	15
1250904	R40	40	15
1250905	R45	45	15
1250906	R50	50	15
1250907	R50	60	15
1250908	R70	70	15
1250909	R80	80	15
1250910	R95	95	15
1250911	R100	100	15
1250912	R110	110	15
1250913	R120	120	15
1250914	R130	130	15
1250915	R140	140	15
1250916	R150	150	15
1250917	R160	160	15
1250918	R170	170	15
1250919	R180	180	15
1250920	R190	190	15
1250921	R200	200	15
1250922	R210	210	15
1250923	R220	220	15
1250924	R230	230	15
1250925	R240	240	15
1250926	R250	250	15
1250927	R300	300	15



SARGENTO DE MARQUETERÍA M Y MM



Ref.	Código	Ref.	Código	Apertura cm	Alcance cm
1251200	01012	1251300	02012	120	7
1251201	01015	1251301	02015	150	7
1251202	01020	1251302	02020	200	7
1251203	01030	1251303	02030	300	7

SARGENTO DE APRIETE MODELO K

Sección de llanta 40 x 10

Ref.	Código	b cm	Alcance cm
1251000	K20	20	30
1251001	K30	30	30
1251002	K40	40	30
1251003	K50	50	30
1251004	K60	60	30
1251005	K70	70	30
1251006	K80	80	30
1251007	K90	90	30
1251008	K100	100	30



SARGENTO MAXIPRESS



Nuevas formas de los cabezales que permiten librar bordes o resaltes, sistema de émbolo con rosca oculta, mango desmontable e intercambiable con engrasador y posicionador.

MORDAZAS EXTENSIBLES ULTRA-RÁPIDAS QUICK-GRIP® EXTREMA PRESIÓN



Ref.	Código	Apertura mandib. (mm)	Profundidad mandib. (mm)
1251100	10505942	150	95
1251101	10505943	300	95
1251102	10505944	450	95
1251103	10505945	600	95
1251104	10505946	900	95
1251105	10505947	1.250	95

Ref.	Código	Apertura cm	Alcance cm
1251400	60020	20	12
1251401	60025	25	12
1251402	60030	30	12
1251403	60035	35	12
1251404	60040	40	12
1251405	60045	45	12
1251406	60050	50	12
1251407	60060	60	12
1251408	60070	70	12
1251409	60080	80	12
1251410	60090	90	12
1251411	60100	100	12
1251412	60110	110	12
1251413	60120	120	12
1251414	60130	130	12
1251415	60140	140	12
1251416	60150	150	12



SARGENTOS DE ACERO FORJADO



Model PAL: Palanca de apriete rápido.

Ref.	Código PAL	Apertura cm	Alcance cm
1251500	30612	60	12
1251501	30616	80	16
1251502	30620	100	20
1251503	30625	120	25
1251504	30630	140	30

Model TRS: Modelo de apriete trasero.

Ref.	Código TRS	Apertura cm	Alcance cm
1251600	30715	80	15
1251601	30730	100	30

SARGENTO DE APRIETE QUICK



Aprieto a una sola mano, reversible y con capacidad de presión de 150 kg.

Ref.	Código TRS	Apertura cm	Alcance cm
1251700	52202	100	80
1251701	52515	150	80
1251702	52530	300	80
1251703	52545	450	80
1251704	52560	600	80

LIMAS

4001 - PUNTA PLANA



Ref.	Código	L
1251800	4001-4 BAS	100
1251801	4001-6 BAS	150
1251802	4001-8 BAS	200
1251803	4001-10 BAS	250
1251804	4001-12 BAS	300
1251805	4001-14 BAS	350
1251806	4001-4 ENT	100
1251807	4001-6 ENT	150
1251808	4001-8 ENT	200
1251809	4001-10 ENT	250
1251810	4001-12 ENT	300
1251811	4001-14 ENT	350
1251812	4001-4 FIN	100
1251813	4001-6 FIN	150
1251814	4001-8 FIN	200
1251815	4001-10 FIN	250
1251816	4001-12 FIN	300
1251817	4001-14 FIN	350

BAS= BASTA • ENT= ENTREFINA • FIN= FINA

4003 - MEDIA CAÑA



Ref.	Código	L
1251900	4003-4 BAS	100
1251901	4003-6 BAS	150
1251902	4003-8 BAS	200
1251903	4003-10 BAS	250
1251904	4003-12 BAS	300
1251905	4003-12 BAS	350
1251906	4003-14 BAS	100
1251907	4003-4 ENT	150
1251908	4003-6 ENT	200
1251909	4003-10 ENT	250
1251910	4003-12 ENT	300
1251911	4003-14 ENT	350
1251912	4003-4 FIN	100
1251913	4003-6 FIN	150
1251914	4003-8 FIN	200
1251915	4003-10 FIN	250
1251916	4003-12 FIN	300
1251917	4003-14 FIN	350

BAS= BASTA • ENT= ENTREFINA • FIN= FINA