

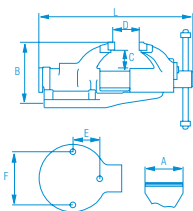

## TORNILLOS DE BANCO

### 601 - TORNILLO DE BANCO



| Ref.    | Código     | L   | A   | B   | C  | D   | E  | F   |
|---------|------------|-----|-----|-----|----|-----|----|-----|
| 1249800 | 6010.00800 | 260 | 80  | 130 | 42 | 80  | 45 | 90  |
| 1249801 | 6010.01000 | 320 | 100 | 166 | 56 | 100 | 45 | 90  |
| 1249802 | 6010.01250 | 375 | 125 | 196 | 72 | 125 | 57 | 115 |
| 1249803 | 6010.01500 | 430 | 150 | 229 | 80 | 150 | 72 | 145 |

### 6072 - TORNILLO DE BANCO

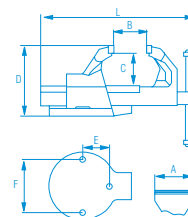

| Ref.    | Código     | A   | B   | C   | D   | L   | grs.   |
|---------|------------|-----|-----|-----|-----|-----|--------|
| 1250100 | 6072.01000 | 100 | 125 | 66  | 122 | 325 | 6.150  |
| 1250101 | 6072.01250 | 125 | 150 | 80  | 152 | 402 | 12.360 |
| 1250102 | 6072.01500 | 150 | 200 | 98  | 182 | 492 | 20.200 |
| 1250103 | 6072.01750 | 175 | 235 | 118 | 211 | 551 | 30.350 |

### 601 - PAREJA DE MORDAZAS Y TORNILLOS



| Ref.    | Código     | A   |
|---------|------------|-----|
| 1249900 | 6010.M0800 | 80  |
| 1249901 | 6010.M1000 | 100 |
| 1249902 | 6010.M1250 | 125 |
| 1249903 | 6010.M1500 | 150 |

### PAREJA DE MORDAZAS Y TORNILLOS



| Ref.    | Código     | A   | grs.  |
|---------|------------|-----|-------|
| 1250200 | 6072.M1000 | 100 | 350   |
| 1250201 | 6010.M1250 | 125 | 450   |
| 1250202 | 6010.M1500 | 150 | 750   |
| 1250203 | 6072.M1750 | 175 | 1.020 |

### 601 - HUSILLO Y TUERCA



| Ref.    | Código     | A   |
|---------|------------|-----|
| 1250000 | 6010.H0800 | 80  |
| 1250001 | 6010.H1000 | 100 |
| 1250002 | 6010.H1250 | 125 |
| 1250003 | 6010.H1500 | 150 |

### 608 - HUSILLO Y TUERCA



| Ref.    | Código     | A   | grs.  |
|---------|------------|-----|-------|
| 1250300 | 6070.H1000 | 100 | 470   |
| 1250301 | 6070.H1250 | 125 | 820   |
| 1250302 | 6070.H1500 | 150 | 1.230 |
| 1250303 | 6070.H1750 | 175 | 2.060 |



### 6010 - MORDAZAS PARA TORNILLO DE BANCO

ACESA PALMERA IRIMO

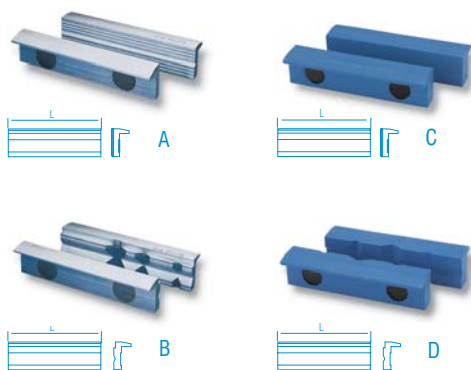

| Ref.    | Código     | L   |   |
|---------|------------|-----|---|
| 1250400 | 6010.A2100 | 100 | A |
| 1250401 | 6010.A2125 | 125 |   |
| 1250402 | 6010.A2150 | 150 |   |
| 1250403 | 6010.A1100 | 100 | B |
| 1250404 | 6010.A1125 | 125 |   |
| 1250405 | 6010.A1150 | 150 |   |
| 1250406 | 6010.P2100 | 100 | C |
| 1250407 | 6010.P2125 | 125 |   |
| 1250408 | 6010.P2150 | 150 |   |
| 1250409 | 6010.P1100 | 100 | D |
| 1250410 | 6010.P1125 | 125 |   |
| 1250411 | 6010.P1150 | 150 |   |

### 604 - TORNILLO DE SOBREMESA

ACESA PALMERA IRIMO

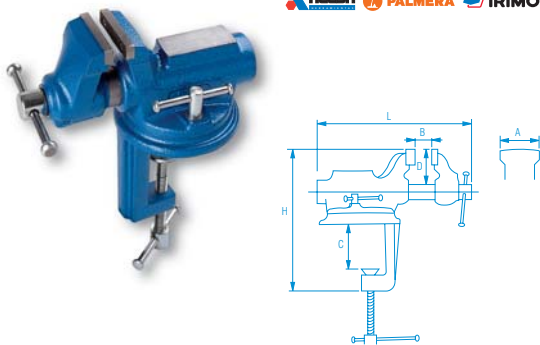

| Ref.    | Código     | L   | A  | B  | C  | D  | H   |
|---------|------------|-----|----|----|----|----|-----|
| 1250500 | 6040.00630 | 210 | 63 | 60 | 75 | 47 | 225 |



### 1B - TORNILLO DE BANCO PARA MECÁNICOS

IRWIN

Novedad



| Ref.    | Código | Anchura mordazas | Profundidad mordazas |   |
|---------|--------|------------------|----------------------|---|
| 1250600 | 1B     | 75               | 50                   | 1 |
| 1250601 | 3B     | 100              | 70                   | 1 |
| 1250602 | 4B     | 115              | 80                   | 1 |
| 1250603 | 5B     | 125              | 85                   | 1 |
| 1250604 | 6B     | 150              | 90                   | 1 |
| 1250605 | 8B     | 205              | 100                  | 1 |

### SARGENTOS

#### SARGENTO DE APRIETE MODELO E

PHER

Sección de llanta 30 x 8

| Ref.    | Código | b cm | Alcance cm |
|---------|--------|------|------------|
| 1250700 | E10    | 10   | 8,5        |
| 1250701 | E15    | 15   | 8,5        |
| 1250702 | E20    | 20   | 8,5        |
| 1250703 | E25    | 25   | 8,5        |
| 1250704 | E30    | 30   | 8,5        |
| 1250705 | E40    | 40   | 8,5        |
| 1250706 | E50    | 50   | 8,5        |
| 1250707 | E60    | 60   | 8,5        |



#### SARGENTO DE APRIETE MODELO F

PHER

Sección de llanta 35 x 8

| Ref.    | Código | b cm | Alcance cm |
|---------|--------|------|------------|
| 1250800 | F20    | 20   | 12         |
| 1250801 | F25    | 25   | 12         |
| 1250802 | F30    | 30   | 12         |
| 1250803 | F35    | 35   | 12         |
| 1250804 | F40    | 40   | 12         |
| 1250805 | F45    | 45   | 12         |
| 1250806 | F50    | 50   | 12         |
| 1250807 | F60    | 60   | 12         |
| 1250808 | F70    | 70   | 12         |
| 1250809 | F80    | 80   | 12         |
| 1250810 | F90    | 90   | 12         |
| 1250811 | F100   | 100  | 12         |
| 1250812 | F110   | 110  | 12         |
| 1250813 | F120   | 120  | 12         |
| 1250814 | F130   | 130  | 12         |
| 1250815 | F140   | 140  | 12         |
| 1250816 | F150   | 150  | 12         |
| 1250817 | F200   | 200  | 12         |

